

RESEARCH ARTICLE

Enhanced reinforcement learning using fuzzy cognitive modeling to analyze mental toughness in college athletes

Dong Li*

Department of Police Physical Education, Zhejiang Police College, Hangzhou, Zhejiang, China.

Received: November 20, 2024; accepted: March 13, 2025.

In the field of competitive sports, psychological resilience is one of the key factors for athletes to succeed in a high-pressure, high-intensity competitive environment. It is particularly important for college athletes who face the dual pressure of academic and sports. However, current research on athletes' psychological resilience is mostly concentrated in the fields of psychology and social sciences. There are few studies on the use of advanced technology systems to improve psychological resilience in practical applications in the field of sports and lack of research on the combination of fuzzy cognitive mapping (FCM) and reinforcement learning (RL). This study explored innovative methods by combining FCM and RL to build a fuzzy cognitive model based on expert knowledge and empirical data, using Python and related libraries to design a reinforcement learning framework based on the Q-learning algorithm, and collecting data through questionnaires and interviews. The results showed that the weight of adversity adaptability in the fuzzy cognitive model was the highest one of 0.3. The average score of psychological resilience in the experimental group after reinforcement learning training increased from 60 to 75, and the key factors were significantly improved, while the control group did not improve significantly. The comprehensive score of psychological resilience of athlete participant increased significantly after training. This study successfully constructed a theoretical and practical method integrating FCM and RL, providing a new perspective for understanding the development of athletes' psychological resilience.

Keywords: fuzzy cognitive model; reinforcement learning; mental toughness; athletes; behavioral strategies.

*Corresponding author: Dong Li, Department of Police Physical Education, Zhejiang Police College, Hangzhou 310053, Zhejiang, China. Email: lidong163@hotmail.com.

Introduction

In the field of competitive sports, psychological resilience is considered one of the key factors for athletes to succeed in high-intensity competition [1]. For college athletes, they have to not only bear academic pressure but also cope with the physical and mental challenges brought by sports training and competition. Strong psychological resilience can help them better cope with failure, overcome obstacles, and thus maintain excellent performance on the field [2]. At present, certain

research results in the field of psychological resilience have been achieved. Studies showed that the ratio of positive and negative emotions had a significant impact on psychological resilience [3]. Through the analysis of the psychological state of athletes, it was found that the balance between positive and negative emotions played a key role in the formation of psychological resilience [4]. In a team environment, the impact of team cohesion on athletes' psychological resilience had also received attention [5]. Studies found that highly

cohesive teams could provide athletes with more support and motivation, thereby enhancing their psychological resilience [6]. Meanwhile, the positive role of a positive attitude in coping with stress had also been deeply explored [7]. Athletes with a positive attitude were often able to adopt more effective coping strategies when facing pressure and maintaining a good competitive state [8].

As important tools in the field of artificial intelligence, fuzzy cognitive mapping (FCM) and reinforcement learning (RL) have been applied in many fields. FCM is a dynamic system model based on expert knowledge, which can effectively simulate the fuzziness and uncertainty in human thinking and has been applied to decision support systems, risk management, and medical diagnosis [9]. In decision support systems, FCM can process complex information and provide decision makers with a more comprehensive reference [10]. RL is a machine learning method that uses a reward mechanism to enable intelligent agents to learn to make optimal decisions in each environment. It has made remarkable achievements in robot control, game artificial intelligence, and autonomous driving [11]. In the field of robot control, RL can enable robots to learn and adjust their behavior autonomously according to environmental changes, thereby improving the efficiency and accuracy of task execution [12]. However, there are still some problems that need to be solved urgently. In the study of improving athletes' psychological resilience, there is still a lack of in-depth and systematic research on how to effectively integrate and apply advanced artificial intelligence technology [13]. Although existing studies have made progress in the influencing factors and technical applications of psychological resilience, research on the organic combination of them is still insufficient [14]. Further, although some studies have used fuzzy logic or reinforcement learning alone to solve problems, there are relatively few studies on the combination of FCM and RL in the field of sports, especially in improving athletes' psychological resilience [15]. At present, the application of FCM

and RL is mainly concentrated in other fields, and the exploration in the field of sports is still in its infancy [16].

This study aimed to explore an innovative method to capture the changes in athletes' psychological state through fuzzy cognitive modeling and use reinforcement learning to guide them to develop more positive and effective coping strategies, so as to enhance the psychological resilience of college athletes [17]. The study identified the key factors affecting psychological resilience and constructed a fuzzy cognitive model based on expert knowledge and empirical data [18]. Python programming language and related libraries such as NumPy, Pandas, scikit-learn, TensorFlow, and Gym library were employed to design and implement a reinforcement learning framework based on the Q-learning algorithm [19]. The key variables and evaluation indicators were defined [20]. This study provided a new perspective for understanding the development of athletes' psychological resilience and filled the knowledge gap in the existing literature on how to systematically improve athletes' psychological resilience [21]. It also provided new methods and ideas for research in the field of sports psychology, and practical tools for coaches, athletes, and related support personnel, helping them to develop more scientific training plans and personal development strategies, thereby improving athletes' competitive performance and promoting personal growth [22].

Materials and methods

Research subjects and data collection

A total of 150 college athletes with 80 males and 70 females, aged from 18 – 25 years old, from five universities including Beijing Sport University (Beijing, China), Shanghai Institute of Physical Education (Shanghai, China), Tsinghua University (Beijing, China), Peking University (Beijing, China), and Zhejiang University (Hangzhou, China) were involved in this study. The participants were in various college majors

including sports, sports education, athletic training, and others and covered the sports of track and field, basketball, soccer, and swimming. The data were collected from September 1, 2023 to June 30, 2024 through questionnaires, in-depth interviews, and psychometric tests covering the athletes' psychological state, daily training, various competition performances, and other aspects. All procedures of this study were approved by the "College Sports Research Ethics Review Committee" (Beijing, China) (Approval No. 20230815-01).

Theoretical framework

To construct a theoretical framework that integrated fuzzy cognitive modeling and reinforcement learning, it first needed to define how mental toughness manifested itself in college athletes, then modeled these manifestations through fuzzy cognitive modeling, and ultimately used reinforcement learning to optimize athletes' behavioral strategies. The mental toughness was defined as an individual's ability to recover quickly and maintain a high level of performance in the face of adversity. The theoretical framework contained two main components, fuzzy cognitive modeling and reinforcement learning. The fuzzy cognitive model was used to model changes in an athlete's mental state, while reinforcement learning was used to optimize an athlete's behavioral strategies to improve his or her mental toughness. To construct a theoretical framework that integrated FCM and RL, a fuzzy cognitive model was constructed based on expert knowledge and empirical data for modeling changes in athletes' mental states. The key factors that affected mental toughness were identified and the causal relationship between these factors was defined. Further, a reinforcement learning environment based on the output of the FCM was defined, where each state corresponded to the athlete's mental state and each action corresponded to a different behavioral strategy adopted by the athlete. To motivate athletes to adopt behaviors that contributed to improving mental toughness, a reward mechanism was also designed, which was

determined based on the change of factors in the FCM, i.e., the athlete would be rewarded when adopting a behavior that led to a change in the mental toughness related factors in a positive direction. A reinforcement learning intelligent was eventually trained to learn and practice more effective coping strategies in a simulated environment. Through continuous experimentation and adaptation, the intelligent body would learn to adopt the most beneficial behaviors under different mental states, and then a theoretical framework that could effectively simulate and optimize mental toughness in college athletes was built [23, 24].

Design of fuzzy cognitive models

FCM is a modeling approach based on expert knowledge and fuzzy logic for simulating and predicting the dynamic behavior of complex systems. In this study, FCM was used to model the changing mental states of college athletes. Based on the literature review and expert interviews, the key factors affecting mental toughness were defined as nodes, which included adversity adaptability, emotion regulation, self-efficacy, and goal-directed behavior. For each pair of nodes i and j , a fuzzy relationship w_{ij} was defined, which indicated the degree of influence of node i on node j . This relationship was determined by expert opinion and empirical data as shown below.

$$x_i(t+1) = f \left(\sum_{j=1}^n w_{ij} x_j(t) \right) \quad (1)$$

where $x_i(t)$ was the state of node i at time t . f was a nonlinear function Sigmoid function to model fuzzy logic. The changes in mental states over time were simulated by iteratively applying the updated rules described above.

Application of intensive learning

To optimize athletes' behavioral strategies using RL, an appropriate reinforcement learning framework should be defined. The Q-learning algorithm was applied as a basis because it does

not require complete information about the environment and is suitable for dealing with complex real-world problems. A Q-table was initialized, where each row represented a state s and each column represented an action a . Initially, all $Q(s, a)$ values were set to 0. At each time step t , the current state s_t was observed and an action a_t was selected based on the current state s_t . The ϵ -greedy strategy was used to balance exploration and exploitation [25]. The action a_t was executed, and the new state s_{t+1} and the immediate reward r_t were observed. the Q-table was updated by using the following equation (2).

$$Q(s_t, a_t) \leftarrow Q(s_t, a_t) + \alpha [r_t + \gamma \max_{a'} Q(s_{t+1}, a') - Q(s_t, a_t)] \quad (2)$$

where α was the learning rate. γ was the discount factor. a' was all possible actions under the next state s_{t+1} . The steps were repeated until the stop condition was met.

Integration strategies

To effectively combine FCM and RL, a fuzzy cognitive model was used to simulate the athlete's mental state, and a RL algorithm was used to optimize the athlete's behavioral strategies. In each simulation, the initial state of RL was defined based on the state output of the fuzzy cognitive model. Each node in the model represented a mental state factor such as the ability to adapt to adversity and the ability to regulate emotions. The state of each node was updated using equation 3.

$$x_i(t+1) = f \left(\sum_{j=1}^n w_{ij} x_j(t) \right) \quad (3)$$

where $x_i(t)$ was the state of node i at time t . f was a nonlinear function such as a Sigmoid function used to model fuzzy logic. w_{ij} was the influence weight of node j on node i . The state output of the fuzzy cognitive model was used as the state input for RL. If the fuzzy cognitive model

predicted a decrease in an athlete's ability to regulate emotions, this would be considered an inefficient state in RL, which needed to be improved by learning new behavioral strategies. If the fuzzy cognitive model predicted a decrease in the athlete's emotional regulation, then in an RL environment, this would be viewed as a state that needed to be improved. Positive rewards were given to athletes if they adopted behaviors that led to an increase in self-efficacy r^+ as shown in equation (4).

$$r^+ = k \cdot (\Delta \text{Self-Efficacy}) \quad (4)$$

where k was the reward coefficient. $\Delta \text{Self-Efficacy}$ was the amount of change in self-efficacy. If the behavior led to a decrease in self-efficacy, a punishment was given as r^- shown below.

$$r^- = -l \cdot (\Delta \text{Self-Efficacy}) \quad (5)$$

where l was the punishment coefficient.

Combining the ideas of fuzzy reasoning and reinforcement learning created a more flexible and adaptable learning framework. Fuzzy reasoning allowed us to make decisions with imprecise information, which enabled the system to deal with uncertainty in the real world. Reinforcement learning was a trial-and-error mechanism that allowed intelligent bodies (Agents) to learn optimal behavioral strategies in their environment. In this combination, the intelligent body not only acted based on the current state but also evaluated uncertain or ambiguous state information using fuzzy reasoning. If the intelligent was in a certain state and needed to decide which action to take, it could evaluate the suitability of different courses of action by means of a fuzzy logic system, even though this information might not be completely clear. The action decision thus obtained would more closely match the complexity and uncertainty of the real world. Subsequently, the intelligent body performed the selected action

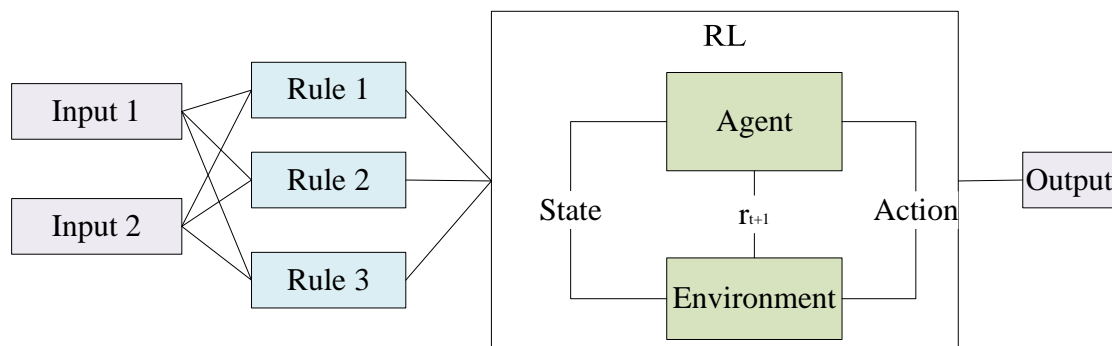

Figure 1. Convergence framework.

and received a reward from the environment R . The reward signal guided the intelligent body to adjust its strategy so that it could make better decisions when it encountered similar situations in the future. Over time, the intelligent body gradually learned to maximize the accumulated rewards in ambiguous environments through a continuous trial-and-error and learning process (Figure 1). This reinforcement learning approach incorporating fuzzy reasoning was ideally suited for applications in complex environments that were difficult to model accurately. During the training process, the parameters of RL were dynamically adjusted according to the output of the fuzzy cognitive model such as the learning rate α and the discount factor γ . When the fuzzy cognitive model showed that the mental toughness of the athlete had improved, the learning rate α was appropriately reduced to reduce the risk of overfitting as shown in equation (6).

$$\alpha_{\text{new}} = \alpha_{\text{old}} \cdot (1 - \beta \cdot \Delta \text{Resilience}) \quad (6)$$

When the fuzzy cognitive model showed that there was no significant change in the mental toughness of the athletes, the discount factor γ was appropriately increased to encourage the intelligentsia to consider the long-term benefits as shown in equation (7).

$$\gamma_{\text{new}} = \gamma_{\text{old}} + \delta \cdot (1 - \gamma_{\text{old}}) \quad (7)$$

where δ was the adjustment factor.

Key factors

To verify the validity and accuracy of the fuzzy cognitive model, the key factors of the fuzzy cognitive model and their weights were analyzed. Five key factors including adversity adaptability, emotion regulation, self-efficacy, goal-oriented behavior, and social support were used, which played important roles in the formation and enhancement of mental toughness in athletes. The weights of those factors indicated the degree of importance of each factor in the model and were assigned as 0.3, 0.25, 0.2, 0.15, and 0.1 for adversity adaptability, emotion regulation, self-efficacy, goal-oriented behavior, and social support, respectively.

Implementation

The study employed the Difficulties in Emotion Regulation Scale (DERS) (American Psychological Association, Washington, DC, USA) in addition to Connor-Davidson Resilience Scale (CD-RISC) (<https://www.connordavidson-resiliencescale.com/>) and the Adversity Adaptability Scale (AAS) (<http://www.chinaaas.com>) to comprehensively evaluate the athletes' psychological resilience-related indicators from different dimensions. CD-RISC focused on overall resilience assessment and was used to measure adversity resilience, while DERS focused on the degree of difficulty in emotion regulation and was used to measure emotion regulation. Self-efficacy was measured using the General Self-Efficacy Scale (GSE) ([https://www.drugsandalcohol.ie/26768/1/General_Self-Efficacy_Scale%20\(GSE\).pdf](https://www.drugsandalcohol.ie/26768/1/General_Self-Efficacy_Scale%20(GSE).pdf)), while goal orientation behavior was measured by the

Goal Orientation Scale (GOS) (<https://scales.arabpsychology.com/s/goal-orientation-scales/>). The athletes' adaptability in adversity was determined by using AAS. All data were cleaned before the fuzzy cognitive model was constructed. The state space and action space of the reinforcement learning environment were then defined followed by designing the reward mechanism. RL intelligence was trained by using the Q-learning algorithm.

Validation of proposed model

The experiment was carried out using Python (<https://www.python.org/>) and related libraries including NumPy (<https://numpy.org/>) and Pandas (<https://pandas.pydata.org/>) for data processing, scikit-learn (<https://scikit-learn.org/>) and TensorFlow (<https://www.tensorflow.org/>) for model training, and the Gym library (<https://gym.openai.com/>) for building the reinforcement learning environment in a simulated environment to record the behavioral changes of the intelligences in different mental states. To further explore the relationship between the key factors of the fuzzy cognitive model and the psychological resilience of athletes, a multi-dimensional research and practice plan was adopted. All participated athletes were divided into groups of track and field, ball games, and water sports according to the sports they played. The improvement differences in key factors of the ability to adapt to adversity, emotional regulation, self-efficacy, goal-oriented behavior, and social support were compared between the groups. Further, the participants were divided into the novice group (1 - 3 year experience) and the senior group (more than 3 year experience) according to the training years and the difference in the improvement of the above key factors of athletes between different training stage groups was analyzed. For athletes whose ability to adapt to adversity improved slowly, the special targeted training plans such as simulated game losses and high-intensity stress training were designed. For athletes with insufficient emotional regulation ability, regular psychological counseling courses and meditation training were arranged.

Meanwhile, based on the improvement of social support factors, a full-scale support network including coaches, teammates, and family members was constructed, and social support was strengthened through regular family interactions, personalized coaching guidance, and teammate mutual aid groups. In addition, in every three months, a psychological scale was used to evaluate changes in athletes' psychological resilience in combination with actual competition performance, and training plans and support strategies were adjusted in a timely manner based on the evaluation results, so as to gain a deeper understanding of the relationship between the key factors of the fuzzy cognitive model and athletes' psychological resilience and provide strong guidance for athletes' training and development. Before RL training, based on the fuzzy cognitive model, through expert knowledge and early small-scale data exploration, the causal relationship and weight between key factors were determined, and then the initial model was constructed. During the training, the RL training was carried out, and a framework was designed based on the Q learning algorithm. The Q-table was initialized with the Q value of all state-action pairs was set to 0. At each step, the agent selected actions using the ϵ -greedy strategy based on the current athlete's psychological state output by the fuzzy cognitive model. The actions covered various training strategies and psychological adjustment methods. After the action was executed, rewards or penalties were given according to the changes in the key factors of the fuzzy cognitive model. The Q value was adjusted by continuous iterative training. After that, the experimental group and the control group were used to collect data again using the same scale and interview method to obtain the key factor data after training.

Results and discussion

Validation of fuzzy cognitive models

The average numerical changes of the five key factors in the fuzzy cognitive model at the initial and the later stages showed that these factors

Table 1. Changes in the mean values of key factors in the fuzzy cognitive model at different stages.

Factor	Average value at initial stage	Average value at later stage
Adaptability to adversity	0.55	0.72
Emotional regulation	0.48	0.63
Self - efficacy	0.60	0.78
Goal - oriented behavior	0.57	0.75
Social support	0.70	0.85

were crucial for assessing the psychological resilience of athletes. Adaptability to adversity increased from 0.55 in the initial stage to 0.72 in the later stage, indicating that athletes' adaptability was significantly enhanced when facing difficulties and challenges. The mean value of emotional regulation increased from 0.48 to 0.63, indicating that athletes had made progress in emotional management and were better able to cope with stress and negative emotions. Self-efficacy increased from 0.60 to 0.78, which meant that athletes' confidence in their abilities had increased significantly, and they believed that they could effectively complete tasks and cope with challenges. Goal-oriented behavior increased from 0.57 to 0.75, indicating that athletes showed stronger determination and persistence in the process of pursuing their goals, and were able to work more concentrate towards their goals. Social support increased from 0.70 to 0.85, reflecting those athletes received more support from their surroundings in the later stages, which helped them maintain a good mental state and competitive level (Table 1). Overall, these data strongly demonstrated the effectiveness of the fuzzy cognitive model in reflecting the improvement of athletes' psychological resilience and provided valuable reference for further research and training.

The trends of the five different psychological indicators over the time showed that adversity adaptation gradually increased from about 0.7 at the beginning to nearly 1.1, reflecting a significant improvement in participants' ability to adapt to adversity. Emotion regulation improved during the first few weeks but then declined and eventually returned to near the starting point, suggesting some fluctuation and challenges in

emotion regulation. Self-efficacy increased slowly but consistently, showing a gradual increase in participants' self-efficacy. Goal-directed behavior went through the process of going from a trough to a peak, especially reaching a peak around week 8, and remained better than the initial state on the whole, despite a slight drop in the later period. Social support remained at a high level with little significant movement, implying relative stability over the period (Figure 2). The results suggested that, except for emotion regulation, all indicators demonstrated different degrees of positive development with particularly strong progress in adversity adaptation and goal-oriented behavior.

Enhancing the effectiveness of learning

To analyze the effect of RL in improving mental toughness of athletes, the mental toughness scores before and after RL training were analyzed. By comparing the average ratings before and after training, the effect of intensive learning on improving mental toughness in athletes was observed with the experimental group's average score increased from 60 to 75 after training, which was a 25% improvement, indicating that RL had a significant effect on improving athletes' mental toughness. On the other hand, the average score of control group only improved from 60 to 62 after training, which was a 3.33% improvement, indicating that the mental toughness of the athletes without RL only improved to a lower degree. The percentage changes of key factors in the experimental and control groups before and after intensive learning training demonstrated that the percentage changes of the experimental group in adversity adaptability, emotion regulation, self-efficacy, goal-oriented behavior, and social

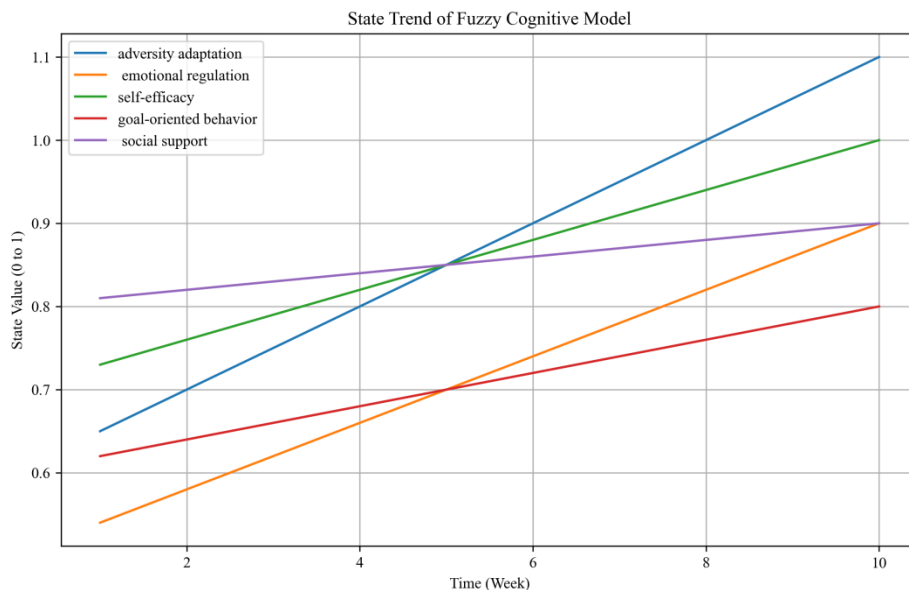

Figure 2. State change trend of fuzzy cognitive model.

Table 2. Changes in key factors before and after intensive learning training.

Key factors	Percentage change	
	Experimental group	Control group
Adaptability to adversity	30%	5%
Emotional regulation	25%	3%
Self-efficacy	20%	4%
Goal-oriented behavior	15%	2%
Social support	10%	1%

support were 30%, 25%, 20%, 15%, and 10%, respectively, which were higher than that of the control group and indicated that RL had a positive effect on improving each key factor of mental toughness in athletes, thus validating the importance of RL in the process of mental toughness development (Table 2). The results confirmed that the mental toughness scores of the experimental group improved significantly after the intensive learning training, especially the two key factors of adversity adaptability and emotion regulation.

The results of this study had important implications for the development of mental toughness in athletes. The fuzzy cognitive model provided a structured framework for assessing and enhancing mental toughness in athletes.

Reinforcement learning, as an effective intervention, significantly increased the level of mental toughness in athletes, which was critical for the long-term development and competitive performance of athletes. From a practical perspective, the findings of this study could be used to guide mental training programs for athletes, particularly in the areas of adversity resilience and self-efficacy. Through targeted training, athletes could be helped to better cope with the stress and uncertainty of competition, thereby improving their competitive performance. This study provided not only a new perspective for understanding the development of mental toughness in athletes but also empirical support for the design and implementation of effective mental toughness development programs, which was an important

contribution to the field of sport psychology as it helped to fill the knowledge gap in the existing literature on how to systematically improve mental toughness in athletes. In addition, this study provided coaches, athletes, and support staff with a set of practical tools to identify and strengthen the weaknesses of athletes' mental toughness, ultimately leading to better athletic performance and personal growth.

Acknowledgements

This study was supported by 2025 Zhejiang Provincial Educational Science Planning Project (Grant No. 2025SCG301).

References

- Xu ZL. 2022. College students' mental health support based on fuzzy clustering algorithm. *Contrast Media Mol Imaging*. 2022(1):5374111.
- Zhao KJ. 2024. Evaluation method for psychological resilience of athletes in high-intensity sports training based on evolutionary neural network. *J Intell Fuzzy Syst*. 46(1):723-737.
- Dong YL. 2019. Comprehensive evaluation analysis of mental health status of poverty-stricken college students at present age with interval-valued intuitionistic fuzzy information. *J Intell Fuzzy Syst*. 37(2):2027-2034.
- Lu SN, Wang SL. 2021. Intelligent monitoring of Taijiquan exercise based on fuzzy control theory. *Microprocess Microsyst*. 2021:103859.
- Zhou DY, Dong DH. 2023. An intelligent model for evaluating college students' mental health based on deep features and a multiview fuzzy clustering algorithm. *J Mech Med Biol*. 23(08):2340079.
- Shvetcov A, Whitton A, Kasturi S, Zheng WY, Beames J, Ibrahim O, *et al*. 2023. Machine learning identifies a COVID-19-specific phenotype in university students using a mental health app. *Internet Interv*. 34:100666.
- Le Glaz A, Haralambous Y, Kim-Dufor DH, Lenca P, Billot R, Ryan TC, *et al*. 2021. Machine learning and natural language processing in mental health: systematic review. *J Med Internet Res*. 23(5):e15708.
- Shatte ABR, Hutchinson DM, Teague SJ. 2019. Machine learning in mental health: A scoping review of methods and applications. *Psychol Med*. 49(9):1426-1448.
- Wang R, Rong X. 2023. Extended group decision making method for quality evaluation of mental health education of college students with hesitant triangular fuzzy information. *J Intell Fuzzy Syst*. 45(2):2835-2845.
- Ahmed U, Lin JCW, Srivastava G. 2022. Fuzzy contrast set based deep attention network for lexical analysis and mental health treatment. *ACM Trans Asian Low-Resour Lang Inf Process*. 21(5):1-16.
- Wang T. 2022. Research on fuzzy comprehensive evaluation index system of mental health education for college students. *J Healthc Eng*. 2022(1):7106926.
- Srividya M, Mohanavalli S, Bhalaji N. 2018. Behavioral modeling for mental health using machine learning algorithms. *J Med Syst*. 42(5):1-12.
- Kodipalli A, Devi S. 2021. Prediction of PCOS and mental health using fuzzy inference and SVM. *Front Public Health*. 9:789569.
- Salabun W, Wieckowski J, Watrobski J. 2022. Swimmer Assessment Model (SWAM): Expert system supporting sport potential measurement. *IEEE Access*. 10:5051-5068.
- Zhang J. 2021. A study on mental health assessments of college students based on triangular fuzzy function and entropy weight method. *Math Probl Eng*. 2021(1):6659990.
- Huang XF, Li H, Zhou H, Krishnamoorthy S, Kadry SN. 2022. Activity classification and analysis during a sports training session using a fuzzy model. *Int J Artif Intell Tools*. 31(05):2250010.
- Rahman HA, Kwicklis M, Ottom M, Amornsriwatanakul A, Abdul-Mumin KH, Rosenberg M, *et al*. 2023. Machine learning-based prediction of mental well-being using health behavior data from university students. *Bioengineering-Basel*. 10(5):575.
- Abd Rahman R, Omar K, Noah SAM, Danuri M, Al-Garadi MA. 2020. Application of machine learning methods in mental health detection: a systematic review. *IEEE Access*. 8:183952-183964.
- Li PP, Dong DD. 2021. Measurement method of college students' mental health level based on K-means algorithm. *Arch Clin Psychiatry*. 48(4):244-251.
- Garcia - Ceja E, Riegler M, Nordgreen T, Jakobsen P, Oedegaard KJ, Torresen J. 2018. Mental health monitoring with multimodal sensing and machine learning: A survey. *Pervasive Mob Comput*. 51:1-26.
- Nash C, Nair R, Naqvi SM. 2023. Machine learning in ADHD and depression mental health diagnosis: A survey. *IEEE Access*. 11:86297-86317.
- Han HY. 2023. Fuzzy clustering algorithm for university students' psychological fitness and performance detection. *Heliyon*. 9(8):e18550.
- Wang ZY, Ouyang Y, Zeng H. 2024. ARFN: An attention-based recurrent fuzzy network for EEG mental workload assessment. *IEEE Trans Instrum Meas*. 73:3369143.
- Deng XY. 2022. A Fuzzy qualitative simulation study of college student's mental health status. *Discrete Dyn Nat Soc*. 2022(1):5177969.
- Zhi LC. 2023. Research on the influence of mental health on college students' employment based on fuzzy clustering techniques. *Soft Comput*. 27(24):19095-19111.